

## Steca AJ

### 275-12, 350-24, 400-48, 700-48, 1000-12, 2100-12, 2400-24

The Steca AJ inverter series stands out with its wide range of available power classes and DC input voltages.

This enables the optimal inverter to be used for any application. The cables for connecting the battery and the load are already mounted on the Steca AJ, thus making it easier to install the device. The automatic standby mode considerably reduces the inverter's own consumption. The Steca AJ inverter's excellent overload capacity ensures that even critical loads can be operated easily.



#### Product features

- True sine wave voltage
- Excellent overload capabilities
- Optimal battery protection
- Automatic load detection
- Best reliability

#### Electronic protection functions

- Deep discharge protection
- Battery overvoltage shutdown
- Short circuit protection
- Overtemperature and overload protection
- Reverse polarity protection by internal fuse (except Steca AJ 2100-12)
- Acoustic alarm at deep discharge or overheating

#### Displays

- Multi-coloured LED shows operating states

#### Operation

- Main switch
- Adjustable load detection

#### Options

- Types with 115 V / 50 Hz, 115 V / 60 Hz or 230 V / 60 Hz
- Model with protective lacquered mainboard
- Remote control JT8 (On/Off, LED) for connection to Steca AJ 1000-12 to Steca AJ 2400-24

#### Certificates

- Compliant with European Standards (CE)
- RoHS compliant
- Made in Europe

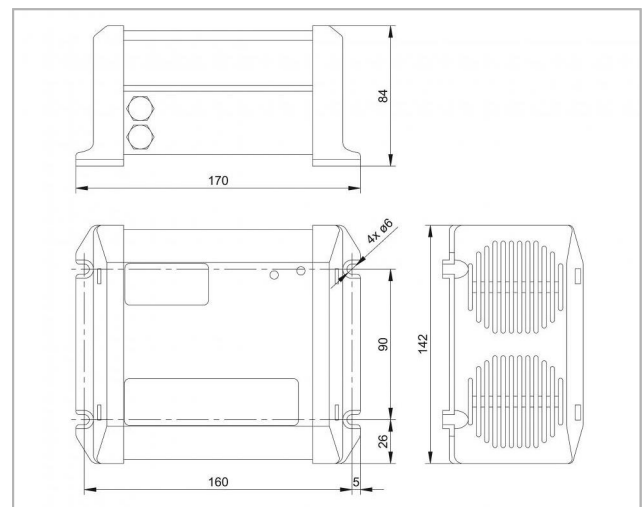

	275-12	350-24	400-48	700-48	1000-12	2100-12	2400-24
<b>Characterisation of the operating performance</b>							
System voltage	12 V	24 V	48 V	48 V	12 V	12 V	24 V
Continuous power	200 VA	300 VA	300 VA	500 VA	800 VA	2000 VA	2000 VA
Power 30 min.	275 VA	350 VA	400 VA	700 VA	1000 VA	2100 VA	2400 VA
Power 5 sec.	450 VA	650 VA	1000 VA	1400 VA	2200 VA	5000 VA	5200 VA
Max. efficiency	93 %	94 %	94 %	94 %	93 %	92 %	94 %
Own consumption standby	0.3 W	0.5 W	1.1 W	1.5 W	0.7 W	0.7 W	1.2 W
Own consumption ON	2.4 W	3.5 W	5.2 W	12.0 W	10.0 W	16.0 W	16.0 W
<b>DC input side</b>							
Battery voltage	10.5 V ... 16 V	21 V ... 32 V	42 V ... 64 V	42 V ... 64 V	10.5 V ... 16 V	10.5 V ... 16 V	21 V ... 32 V
<b>AC output side</b>							
Output voltage	230 V AC $\pm 10\%$ (true sine wave)						
Output frequency	50 Hz $\pm 0.05\%$ (crystal controlled)						
Load detection (standby)	2 W	2 W	2 W	adjustable: 1 W ... 20 W	adjustable: 1 W ... 20 W	adjustable: 1 W ... 20 W	adjustable: 1 W ... 20 W
<b>Operating conditions</b>							
Ambient temperature	-20 °C ... +50 °C						
<b>Fitting and construction</b>							
Cable length battery / AC	1.2 m / 1 m	1.2 m / 1 m	1.2 m / 1 m	1.5 m / 1 m	1.5 m / 1 m	1.7 m / 1 m	1.7 m / 1 m
Degree of protection	IP 30	IP 30	IP 30	IP 30	IP 30	IP 20	IP 20
Dimensions (X x Y x Z)	170 x 142 x 84 mm	170 x 142 x 84 mm	170 x 142 x 84 mm	252 x 142 x 84 mm	455 x 142 x 84 mm	406 x 273 x 117 mm	406 x 273 x 117 mm
Weight	2,4 kg	2,6 kg	2,6 kg	4,5 kg	8,5 kg	19 kg	18 kg