



ZBENY

RSD TRANSMITTER(BFT-01) - OUTDOOR KIT

Rapid Shutdown Activator for BFS-21/22

The BENY Rapid Shutdown Device (RSD) Transmitter is part of a rapid shutdown solution when paired with BENY BFS-21/22 (Fire Safety), a PV module rapid shutdown unit. While powered on, the RSD Transmitter sends a signal to the BFS-21/22 units to keep their PV modules connected and supplying energy.

BFS-21/22 units automatically enter rapid shutdown mode when the RSD Transmitter is switched off and resume energy production when power is restored to the RSD Transmitter. This solution complies with NEC 690.12 specifications for 2014, 2017, and 2020 and uses PLC signaling for rapid shutdown.

The RSD Transmitter Outdoor Kit includes an RSD Transmitter, outdoor enclosure, 100-240VAC power supply, and one or two RSD Cores.

Panel Voltage $\geq 40V$

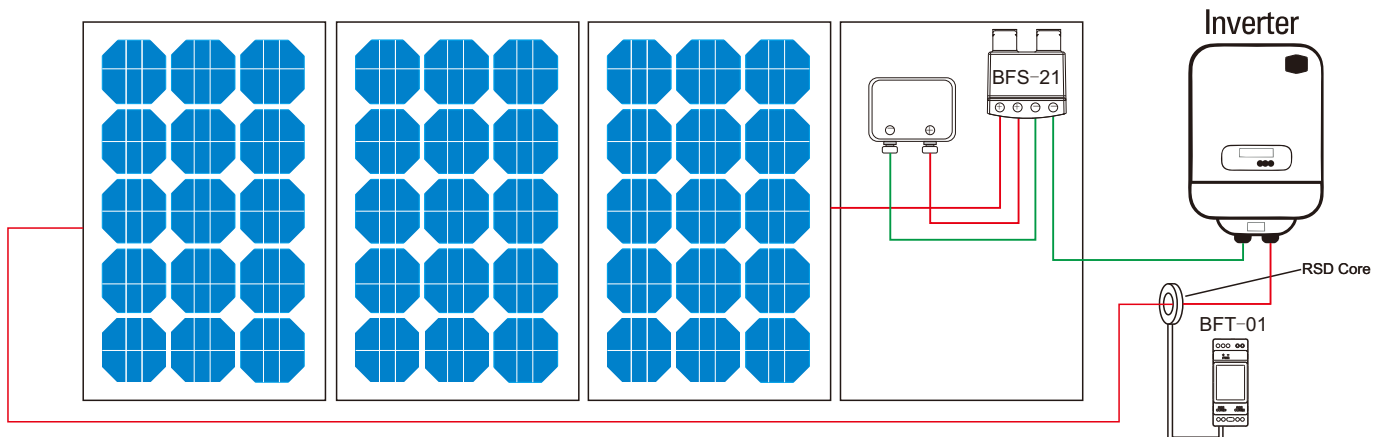

Panel Voltage $< 40V$

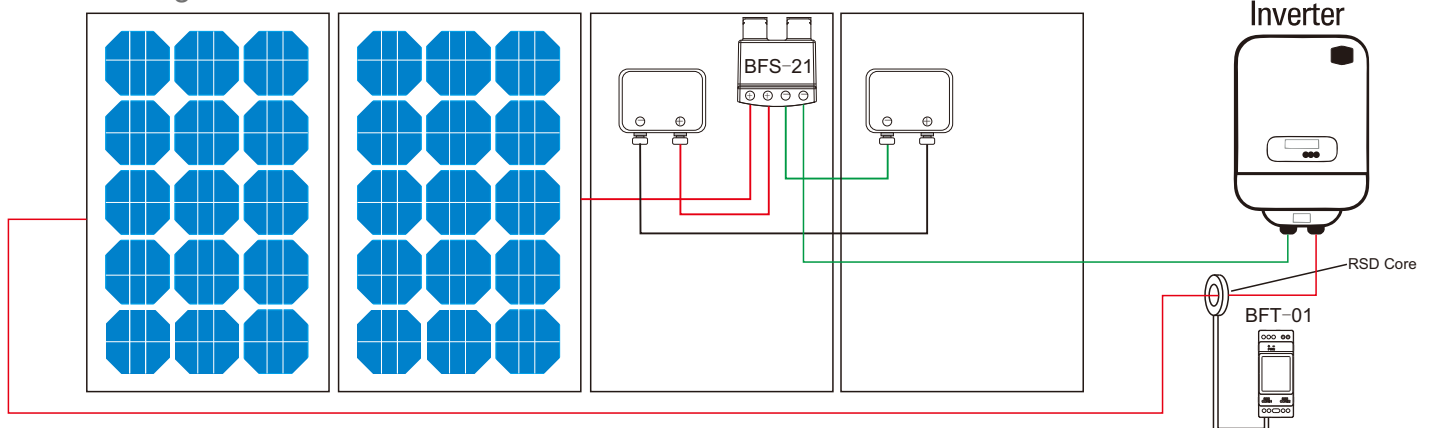

BFT-01 INSTALLATION-SINGLE RSS CORE

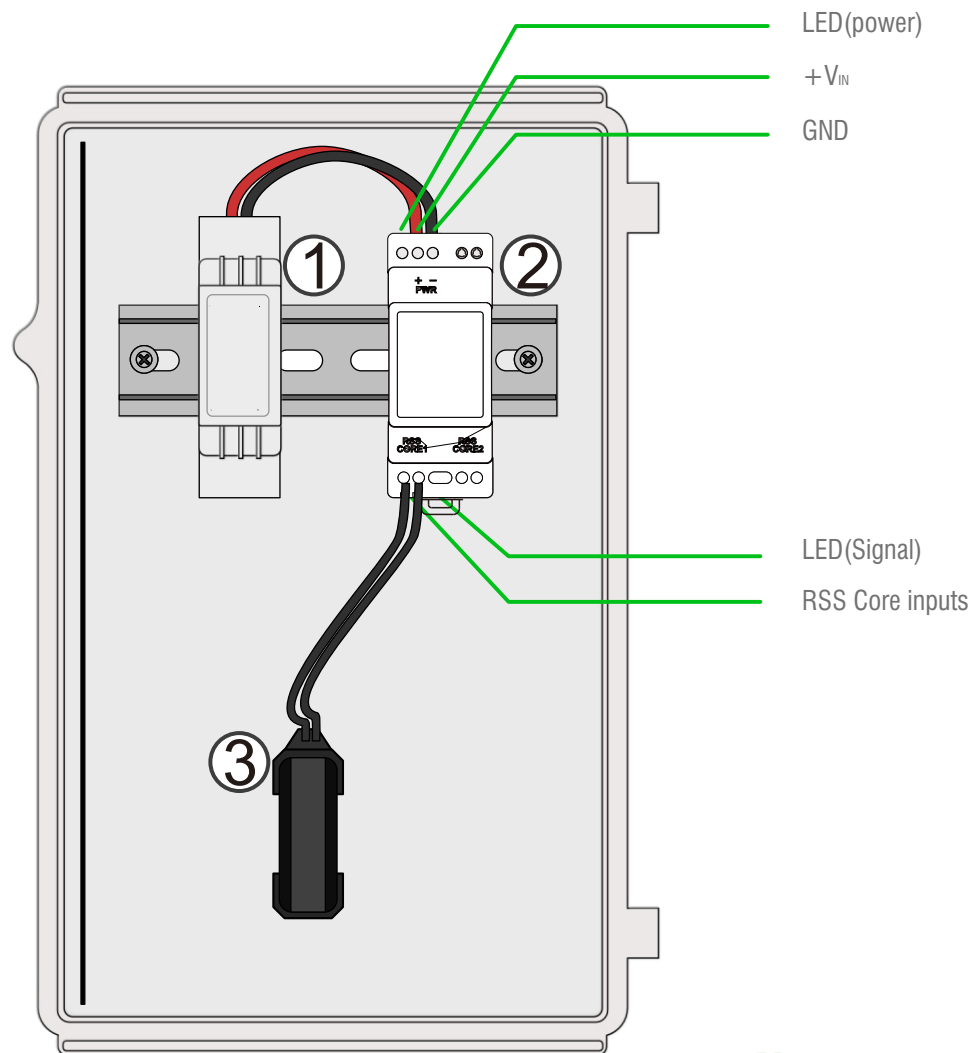

- Transmitter power supply must be on same AC branch circuit as inverter to meet rapid shutdown requirements!

Note: Install Transmitter enclosure before powering on BFT-01

- Drill holes in enclosure for conduit (see drilling guide for placement)
- Mount BFT-01 and power supply on DIN rail
- Connect DC leads from power supply ① to transmitter ②
- Connect RSS Core ③ to transmitter

Place rapid shutdown system label no more than 1m (3ft) from RSS Transmitter or AC disconnect if not at same location.

BFT-01 WIRIN-SINGLE RSS CORE

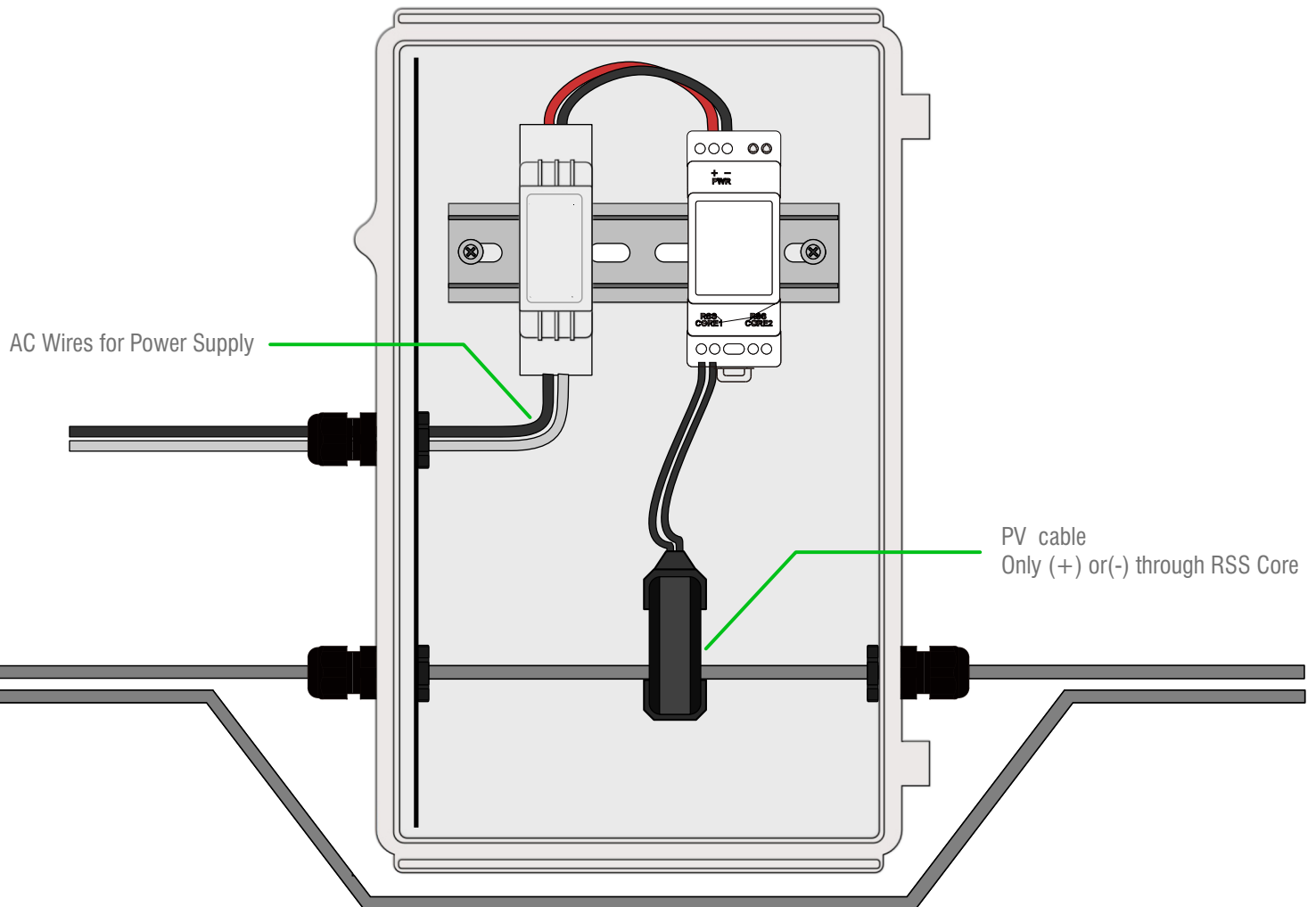

- Note: Install Transmitter enclosure before powering on BFT-01
 - Pass either positive or negative homerun through RSS Core.
 - Connect wires to AC side of power supply

Max number of strings per RSS Core: 10

Max string length: 25 modules

Max current per RSS Core: 180A

Max cable length from inverter (+) to inverter (-): 1000ft (300m)

BFT-01 INSTALLATION DUAL RSS CORE

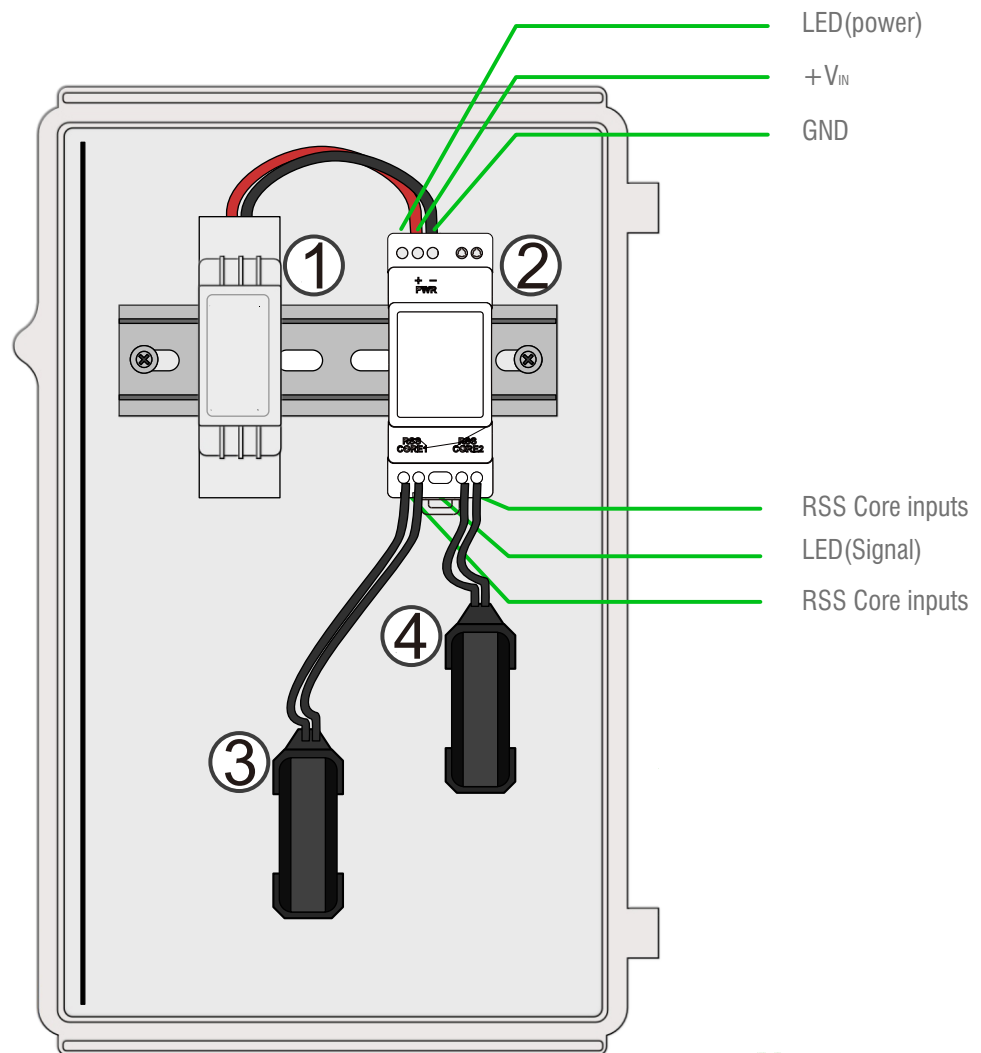

- Transmitter power supply must be on same AC branch circuit as inverter to meet rapid shutdown requirements!

Note: Install Transmitter enclosure before powering on BFT-01

- Drill holes in enclosure for conduit (see drilling guide for placement)
- Mount BFT-01 and power supply on DIN rail
- Connect DC leads from power supply ① to transmitter ②
- Connect RSS Core ③ and ④ to transmitter

Place rapid shutdown system label no more than 1m (3ft) from RSS Transmitter or AC disconnect if not at same location.

BFT-01 WIRING DUAL RSS CORE

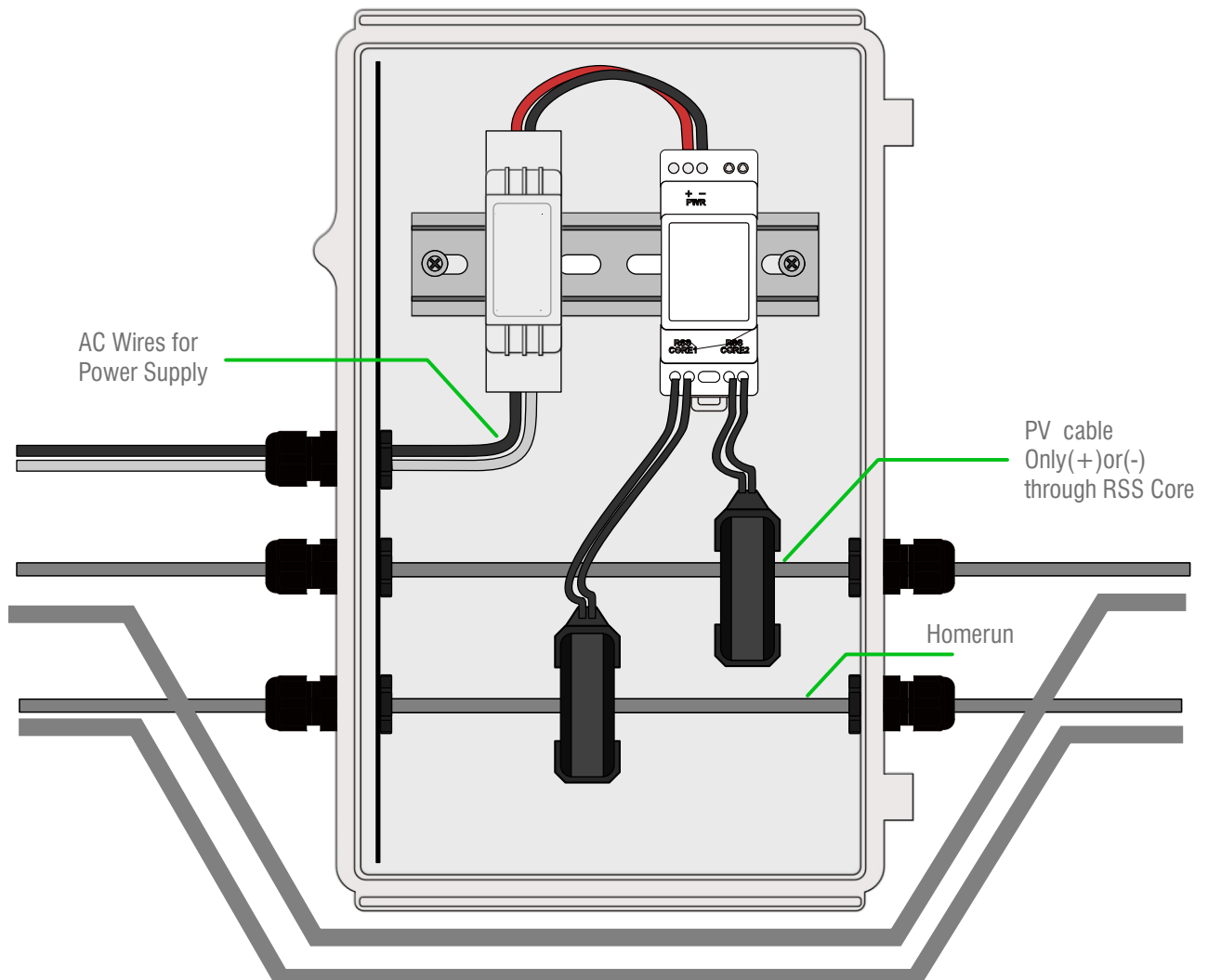

Keep same polarity for all homeruns and RSS Cores throughout the installation

Note: Install Transmitter enclosure before powering on BFT-01

- Pass either positive or negative homerun through RSS Core.
- Connect wires to AC side of power supply

Max number of strings per RSS Core: 10

Max string length: 25 modules

Max current per RSS Core: 180A

Max cable length from inverter (+) to inverter (-): 1000ft (300m)

BFT-01 INSTALLATION-SINGLE DUAL RSS CORE

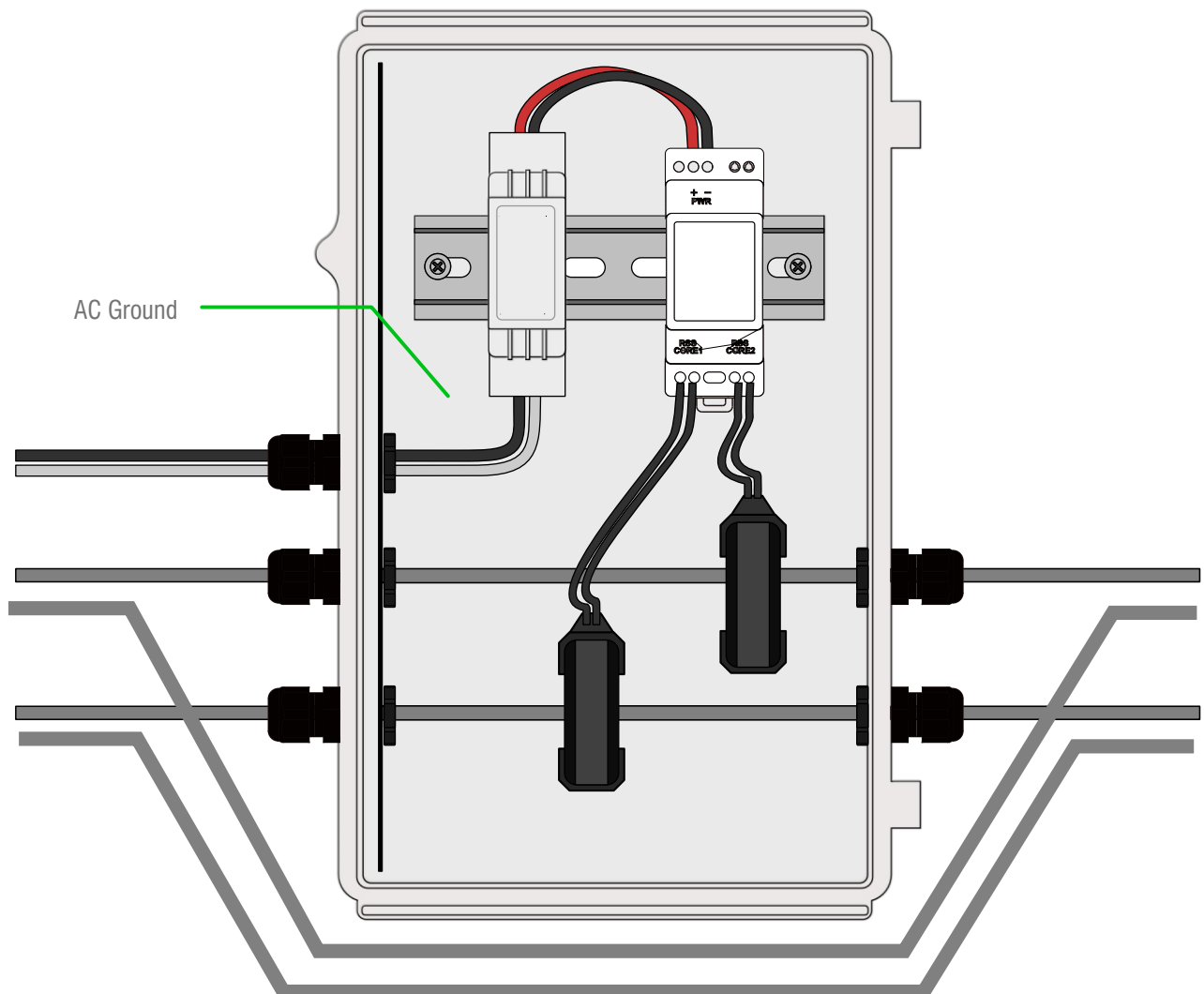

- Note: Install Transmitter enclosure before powering on BFT-01
 - Connect AC and DC ground wires to DIN rail
 - Turn on AC power to Transmitter power supply to activate keep-alive signal and energize PV array



nonmetallic enclosure does not provide bonding between conduit connections. Use grounding type bushings and jumper wires.

BFT-01 INSTALLATION-SINGLE DUAL RSS CORE

200-480V^{AC} Power Supply

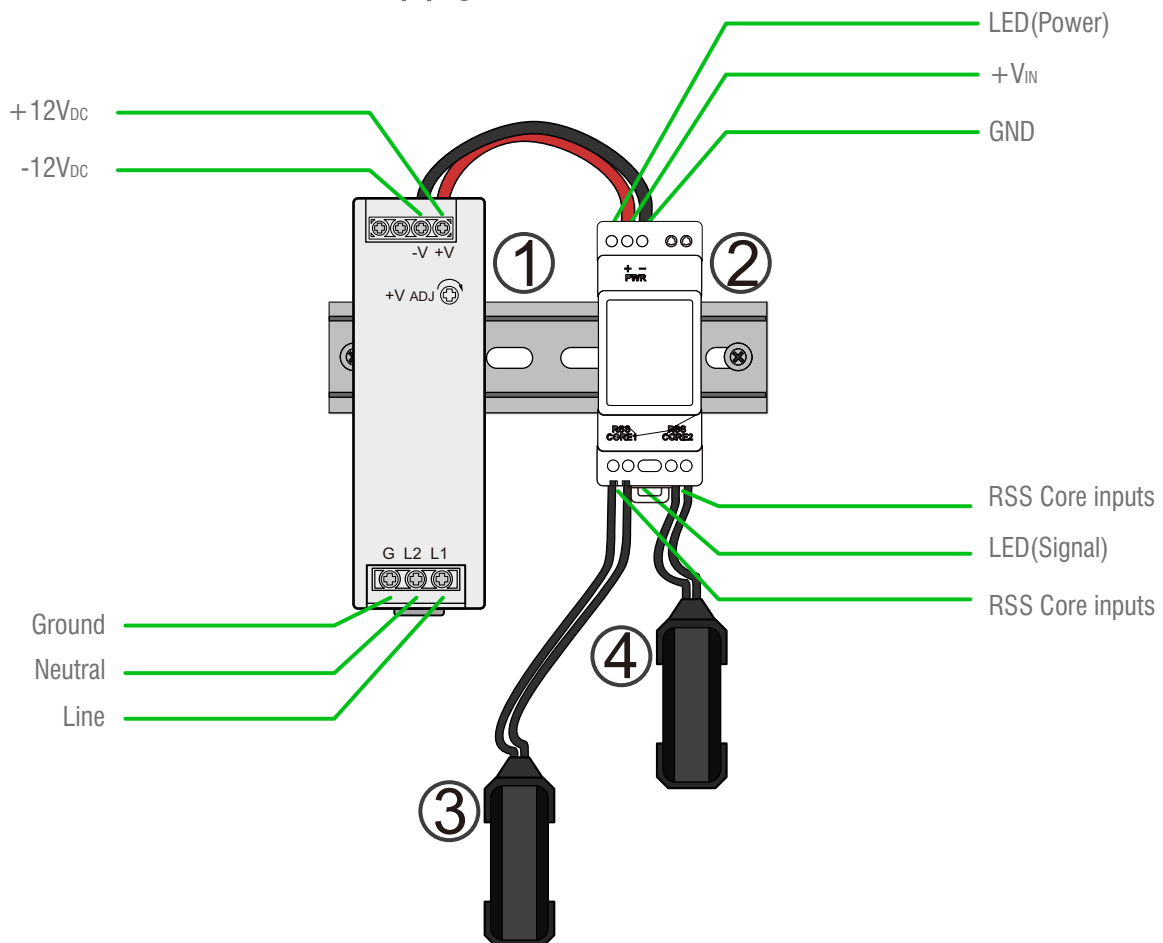

Transmitter power supply must be on same AC branch circuit as inverter to meet rapid shutdown requirements!

Note: Install Transmitter enclosure before powering on BFT-01

- Mount BFT-01 and power supply on DIN rail
- Connect DC leads from power supply ① to transmitter ②
- Connect BFT-01 Core ③ and ④ to transmitter

Place rapid shutdown system label no more than 1m (3ft) from BFT-01 or AC disconnect if not at same location.

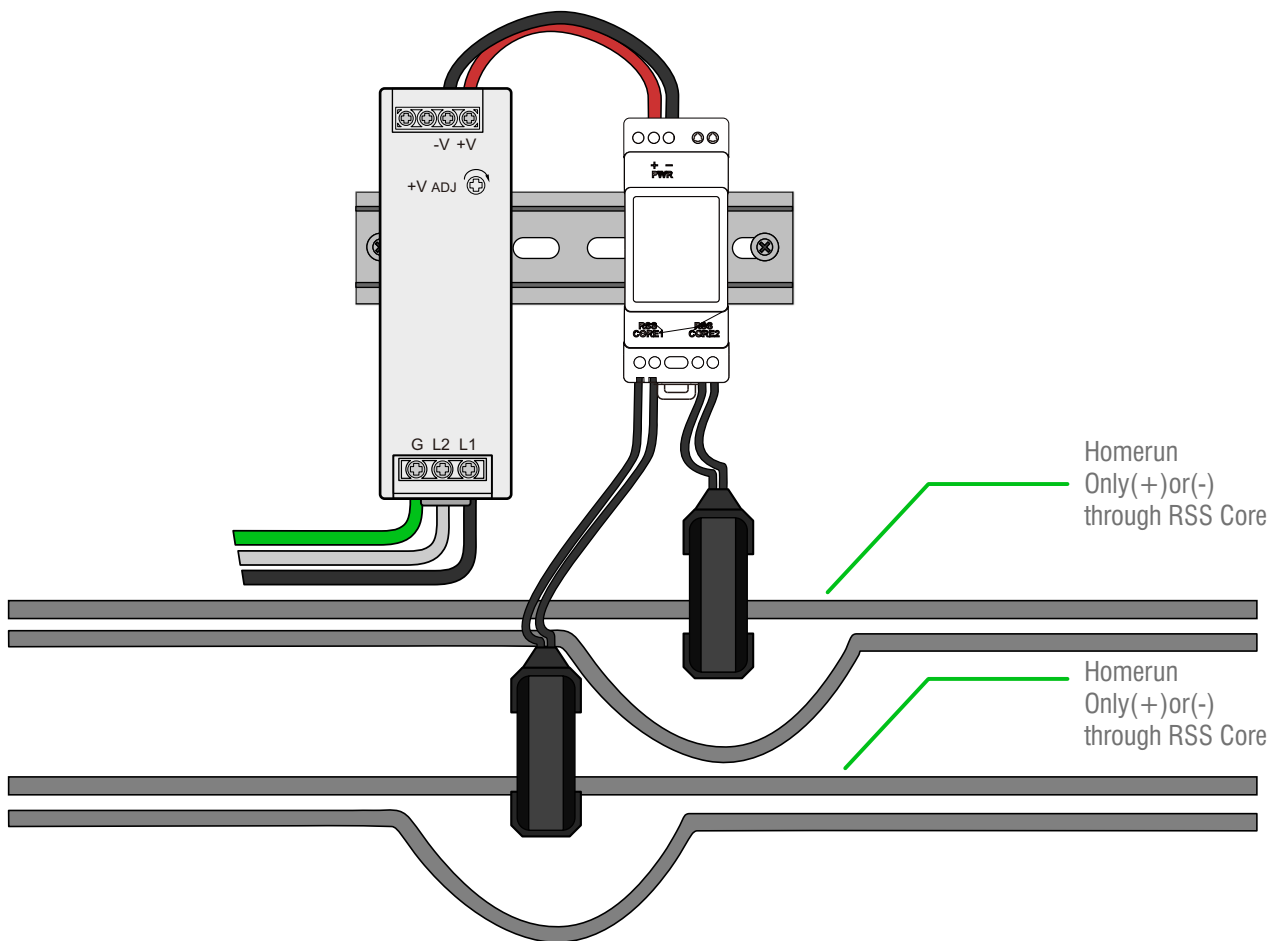

Keep same polarity for all homeruns and RSS Cores throughout the installation

Note: Install Transmitter enclosure before powering on BFT-01

- Pass either positive or negative homerun through RSS Core.
- Connect wires to AC side of power supply

Max number of strings per RSS Core: 10

Max string length: 25 modules

Max current per BFT-01 Core: 180A

Max cable length from inverter (+) to inverter (-): 1000ft (300m)

BFT-01	
Max Working Voltage (DC):	12V
Max Working Current :	1A
Average Supply Power	0.85W
Installation method:	DIN-rail mounting
Storage/shipping Temperature range:	-30°C to +60°C
Operating Ambient Temperature range:	-30°C to +60°C
RSD Core	
Maximum Current	180A per Core(Single Core:180A,Dual Core:360A)
Maximum MPPT String Voltage	1500VDC
Inside Dimension of RSD Core	25mm
Installation method:	DIN-rail mounting
Maximum Number of Strings per Core	10
Maximum Supported RSD Per String	25
Temperature :	-30°C to +60°C

Max number of strings per RSD Core: 10
 Maximum Supported RSD Per String : 25
 Max current per BFT-01 Core: 180A
 Max cable length from inverter (+) to inverter (-): 1000ft (300m)

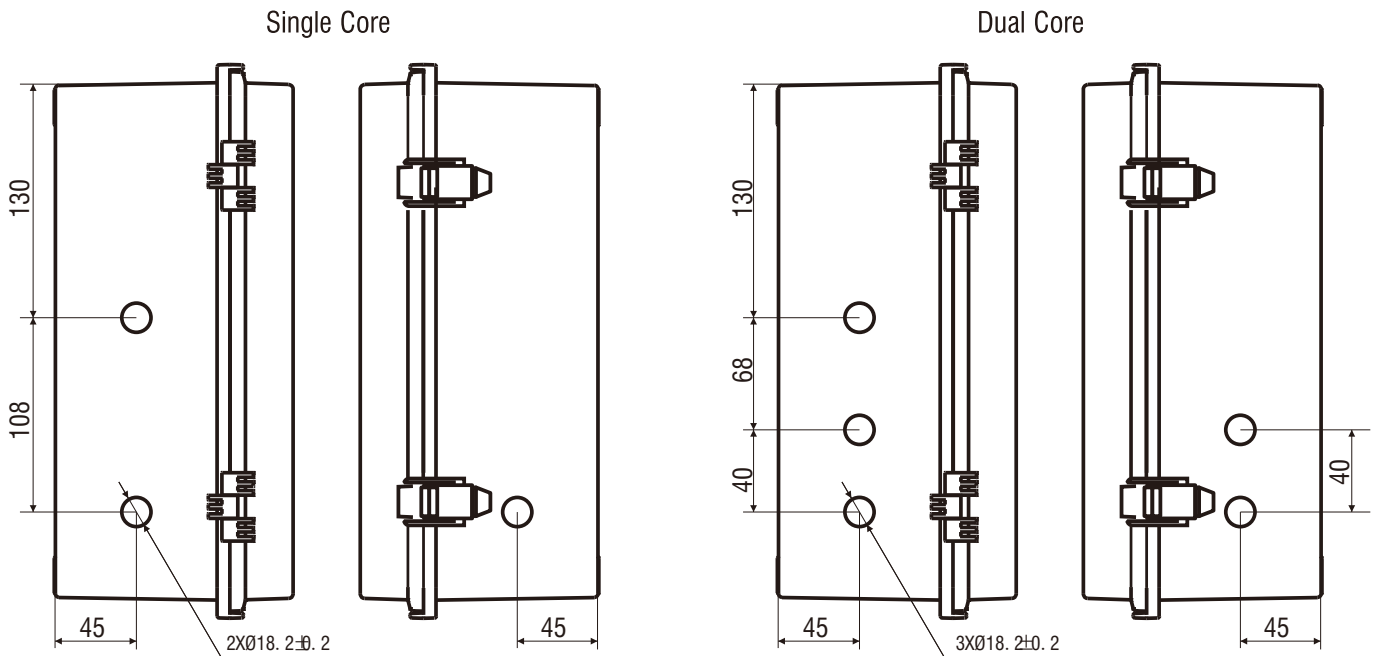

Applicable waterproof joint:PG11